

R-100 Paste Reservoir

For high volume paste storage/dispensing

The R-100 Reservoir is recommended for applications where fast refilling and visual monitoring of the paste alloy level is desired. In production, the R-100 permits nearly 200 oz. of paste to be dispensed without interruption. Paste is packaged in special jars which incorporate a thin "follower" at the bottom.

The paste jar is screwed into the reservoir adapter. Then the clear plastic housing is clamped in place, which causes a sharp tube to pierce the base of the jar. Air pressure is introduced directly to the inverted jar, causing the follower to move paste into the reservoir below.

Advantages of the R-100 Reservoir:

- Not necessary to manually remove paste from the jar.
- Transparent plastic housing permits observation of the paste level.
- After the jar empties, it is replaced with a fresh 100 oz. supply in minutes, minimizing production downtime.

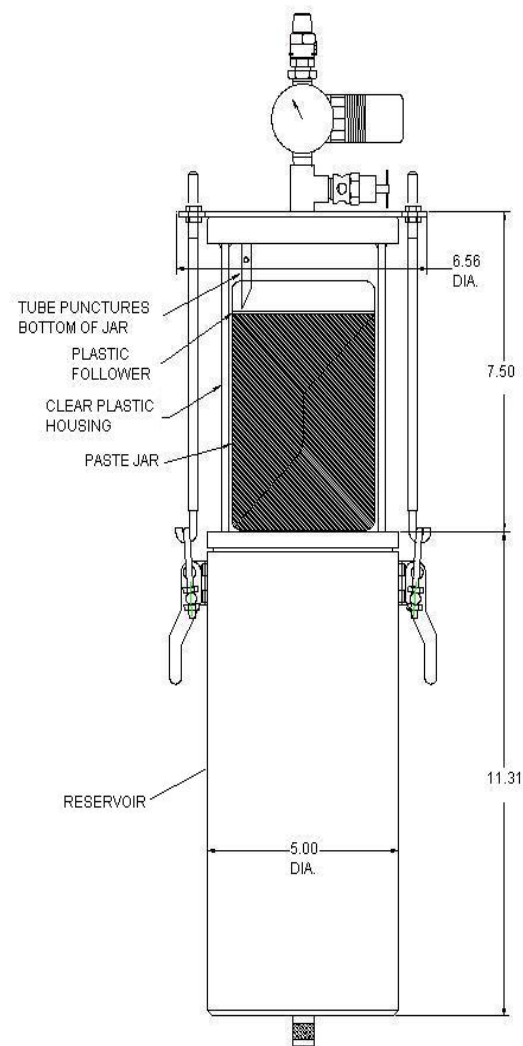

FUSION INCORPORATED

4658 E. 355th St., Willoughby, OH 44094

Phone 1-800-626-9501 • (440) 946-3300

Fax (440) 942-9083 • e-mail: info@fusion-inc.com

Web: www.fusion-inc.com